

Challenge

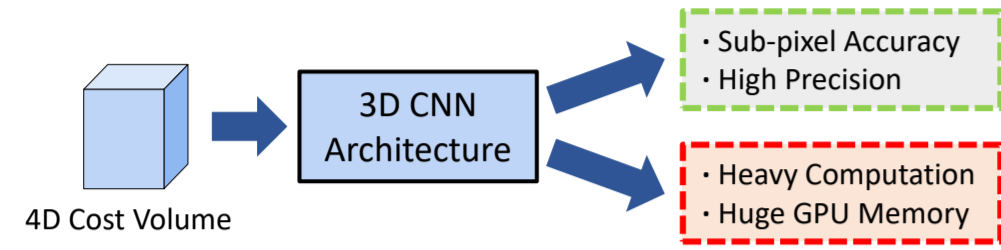

Problem statement

Can we have the best of both worlds and reduce computation cost while achieving high performance?

Contribution

- We propose a **fast and lightweight** end-to-end network for light field disparity estimation.
- We present a **physical-based multi-disparity-scale network** for fast and high-performance cost volume regularization.
- We design an **edge guidance sub-network** to guide the disparity estimation with edge cues for better performance on challenging regions.



$$C(d, h, w) = \frac{1}{N} \langle F_c(c, h, w), f_{\text{warp}}[F_s(c, h, w), d] \rangle$$

Only use 2-streams input images Abandon 3D CNN architecture

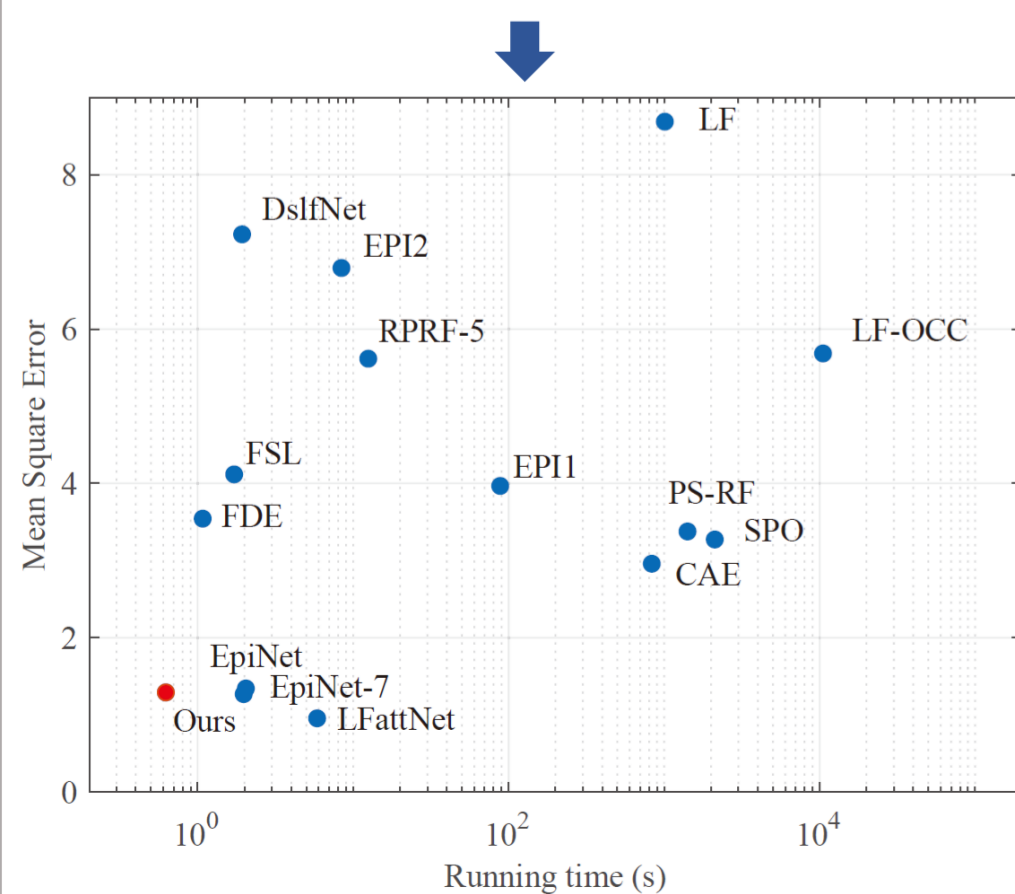

Method

Fast Light-field Disparity Estimation Network (FastLFnet)

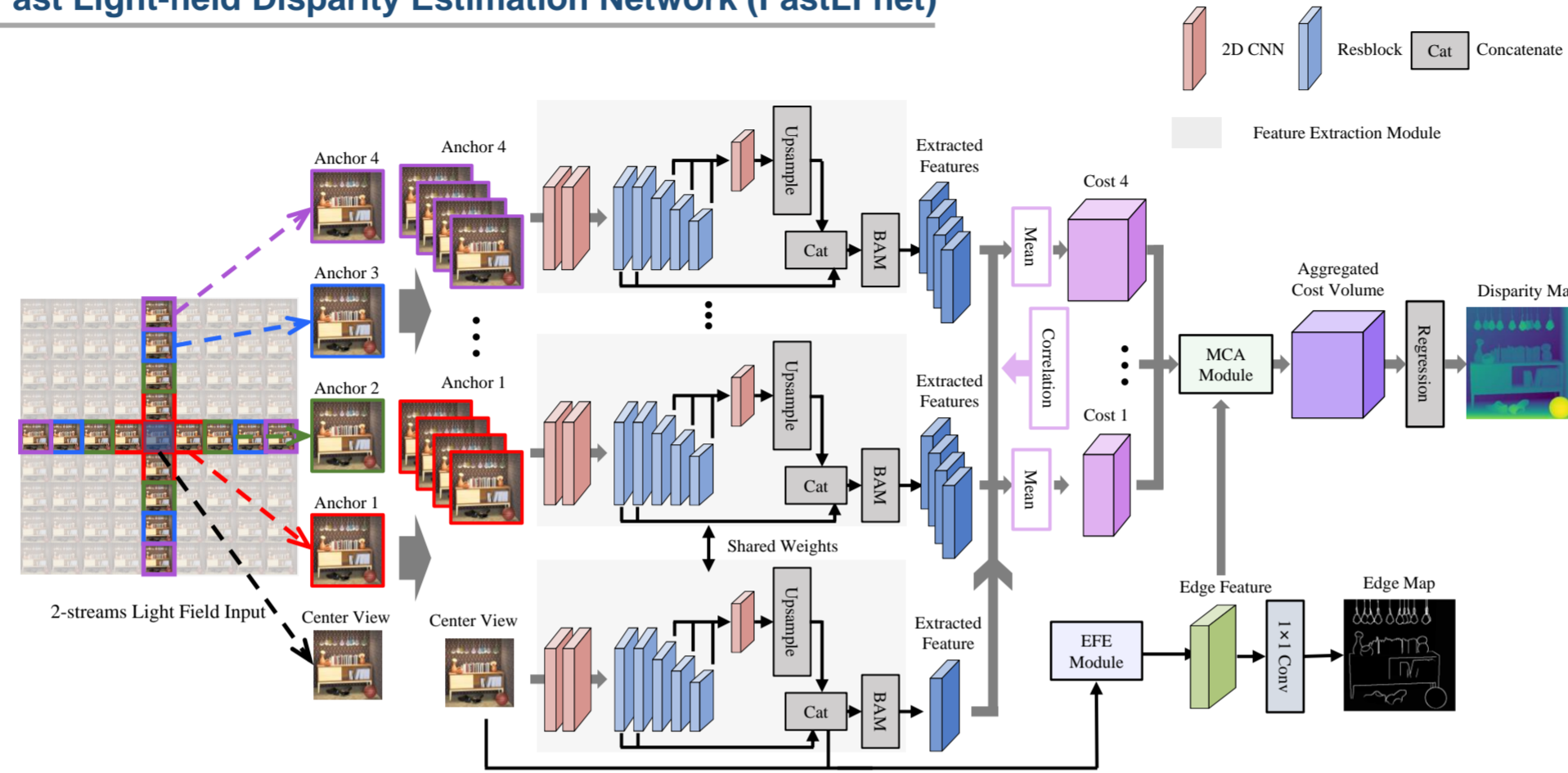

Edge Feature Extraction (EFE) Module

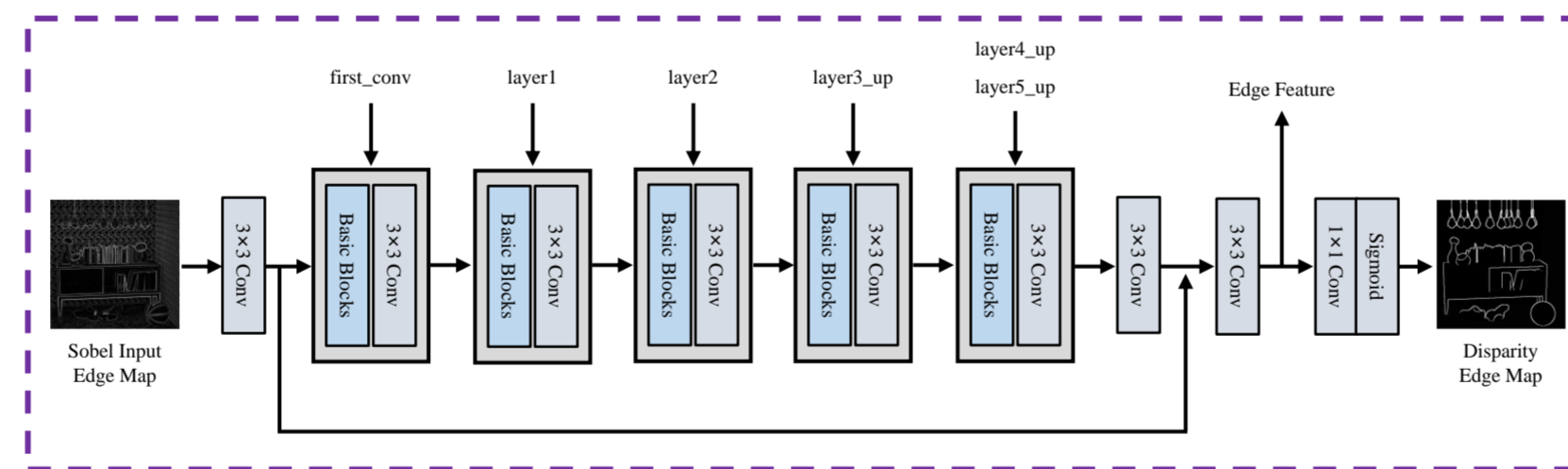

Multi-disparity-scale Cost Aggregation (MCA) Module

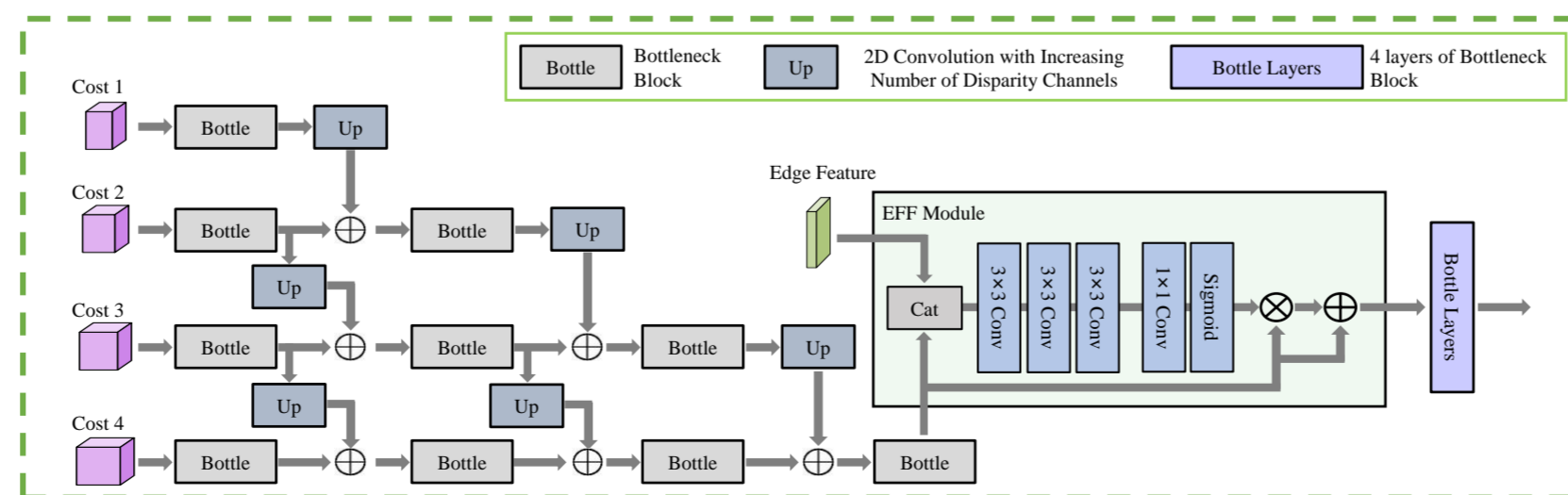

Experiments

4D light field dataset

- Comparison of the contributions of each component

Processing methods	One Scale	w/o BAM	w/o Edge	FastLFnet
MSE_x100	1.650	1.492	1.844	1.218
Running time / s	0.725	0.582	0.576	0.593
GPU Memory / GB	2.323	2.103	2.189	2.107
Parameters / M	1.281	1.361	0.982	1.366

- Quantitative comparison with state-of-the-art methods

Methods	CAE [21]	PS_RF [11]	RPRF-5 [8]	EpiNet-7 [27]	EpiNet [27]	LFattNet [29]	w/o Edge	FastLFnet
Boxes	8.162	8.771	10.333	6.042	5.845	3.869	5.658	4.260
Cotton	1.704	1.227	0.949	0.206	0.235	0.220	0.318	0.339
Dino	0.376	0.730	0.603	0.162	0.147	0.090	0.350	0.184
Sideboard	0.860	1.899	1.224	0.814	0.794	0.518	1.070	0.742
Backgammon	4.762	5.559	3.024	1.500	1.893	1.762	2.658	1.488
Dots	4.589	7.881	20.114	1.155	1.549	0.959	4.508	3.070
Pyramids	0.047	0.043	0.042	0.008	0.007	0.004	0.010	0.018
Stripes	3.171	0.905	8.643	0.265	0.264	0.220	0.854	0.231
Average	2.959	3.377	5.616	1.269	1.342	0.955	1.928	1.291
Fattening	7.614	6.597	5.262	4.702	4.990	3.810	5.752	4.300
Thinning	1.153	2.237	2.568	1.548	1.430	2.230	3.499	2.427
Running time / s	832.081	1412.623	12.498	1.976	2.041	5.862	0.611	0.624
GPU Memory / GB	-	-	-	4.319	5.103	10.953	2.189	2.107
Parameters / M	-	-	-	5.116	5.118	5.058	0.982	1.366

- Qualitative comparison results

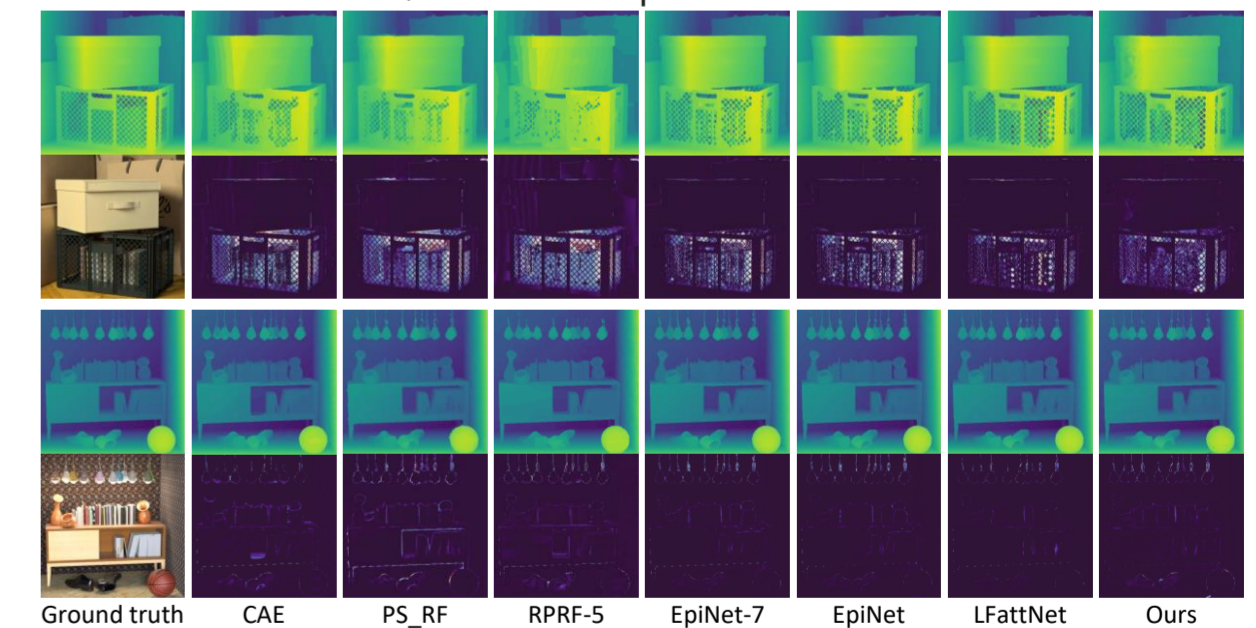

Sparse light field dataset

- Results of the performance comparison

Light fields	MSE					
	EBSM [9]	OHLF [13]	StfNet [6]	EpiNet [27]	DslfNet [26]	FastLFnet
Furniture	0.37	1.94	9.18	1.73	0.42	0.17
Lion	0.10	0.87	1.59	3.41	0.09	0.05
Toy_bricks	0.22	1.10	3.70	0.36	0.57	0.16
Elec_dev	0.20	0.63	7.82	0.74	0.20	0.09
Average	0.22	1.14	5.57	1.56	0.32	0.12